

REVERSABLE TILT-TRIM MOTORS

Today's tilt-trim motors use wire wound or permanent magnet fields.
BEFORE YOU CAN ACCURATELY TEST THE MOTOR YOU MUST KNOW WHAT TYPE IT IS.

Wire wound field motors will normally have three wires and will usually have four screws placed around the perimeter of the motor case. If the motor has only two wires; it is usually a permanent magnet field motor. However, some older Mercury Marine wire wound field motors have only two wires and use an external ground that is attached to the motor housing. Since wire wound field motors have a higher current draw, solenoids are used to relay battery current to the motor. Permanent magnet field motors draw much less current and miniature relays are used to relay the battery current.

REMEMBER - BLUE SKY (UP) WIRE TO POSITIVE MAKES THE MOTOR RUN IN THE UP DIRECTION
GREEN GRASS (DOWN) WIRE TO POSITIVE MAKES THE MOTOR RUN IN THE DOWN DIRECTION

Wire Wound Field Motor

Connecting the blue lead to battery positive and the black lead to battery negative will make the motor run in the up direction and will raise the outdrive or outboard motor.

Connecting the green wire to battery positive and the black wire to battery negative will make the motor run in the down direction. This will lower the outdrive or outboard motor.

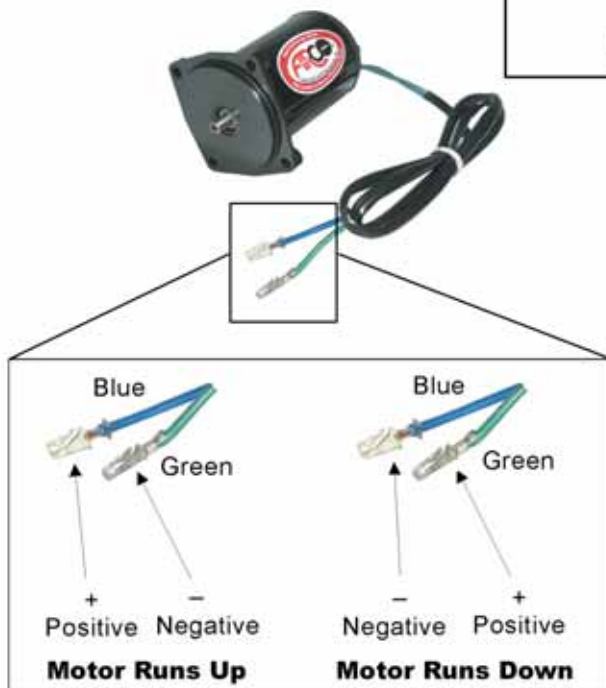
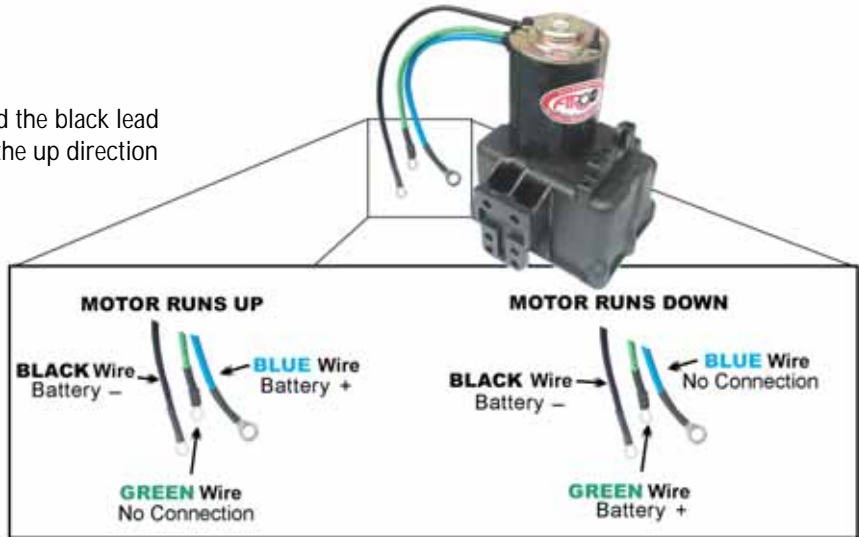

Permanent Magnet Field Motor

Connecting the blue lead to battery positive and the green lead to battery negative will make the motor run in the up direction. This will raise the outdrive or outboard motor.

Connecting the green lead to battery positive and the blue lead to battery negative will make the motor run in the down direction. This will lower the outdrive or outboard motor.

TILT-TRIM MOTOR REVERSING RELAYS

PERMANENT MAGNET FIELD MOTORS

▲ Motor Running In The Up Direction

When the tilt-trim switch is moved to the up position, relay #2 activates supplying positive voltage to the blue wire by connecting terminal #87 to terminal #30.

Relay #1 remains in the off position. Terminal #87a and #30 are connected when the relay is in the off position. This allows the green wire to be connected to battery negative.

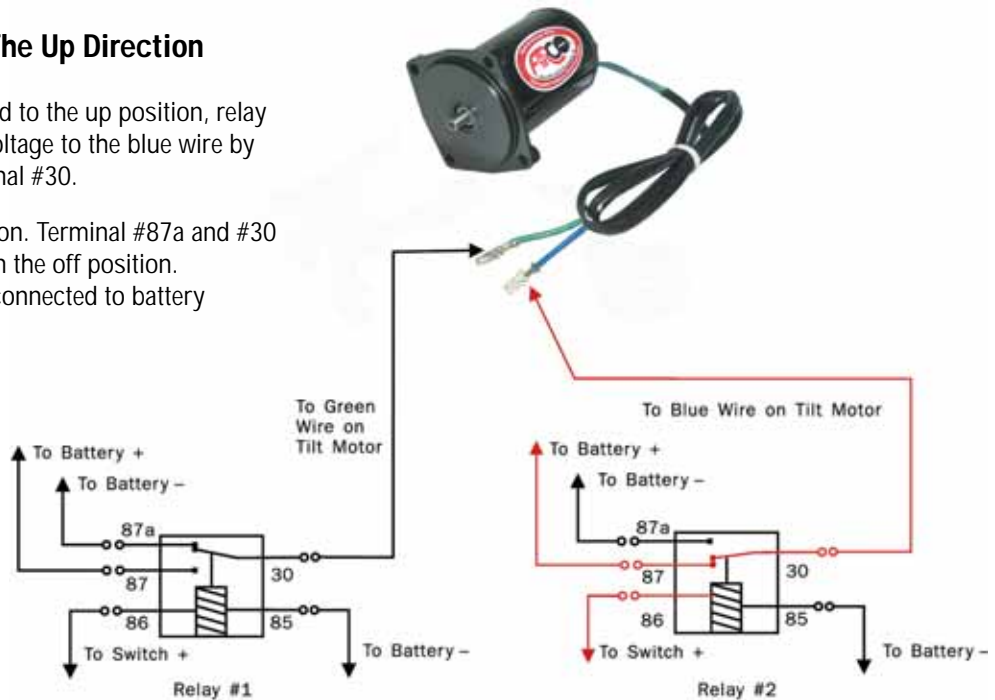

▼ Motor Running In The Down Direction

When the tilt-trim switch is moved to the down position, relay #1 activates supplying positive voltage to the green wire by connecting terminal #87 to terminal #30.

Relay #2 remains in the off position. Terminal #87a and #30 are connected when the relay is in the off position. This allows the blue wire to be connected to battery negative.

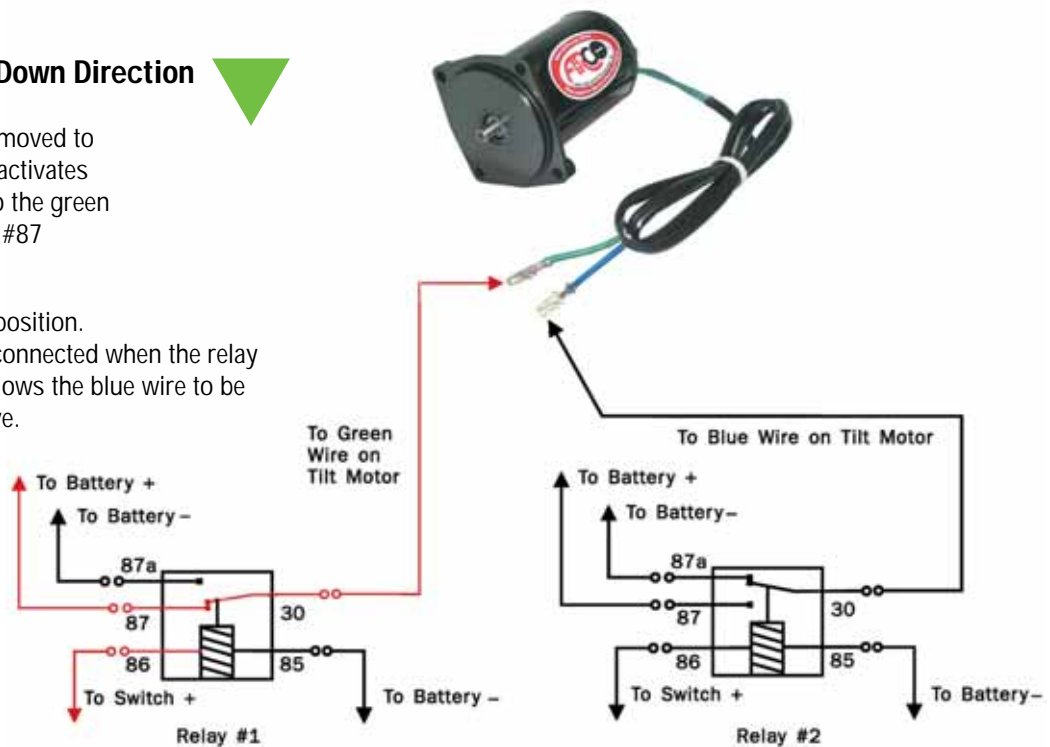

TILT-TRIM MOTOR SOLENOIDS

WIRE WOUND FIELD MOTORS

▲ Motor Running In The Up Direction

When the tilt-trim switch is in the up, position solenoid #2 is energized and battery positive voltage is supplied to the blue wire making the motor run in the up direction. This raises the outdrive or outboard motor.

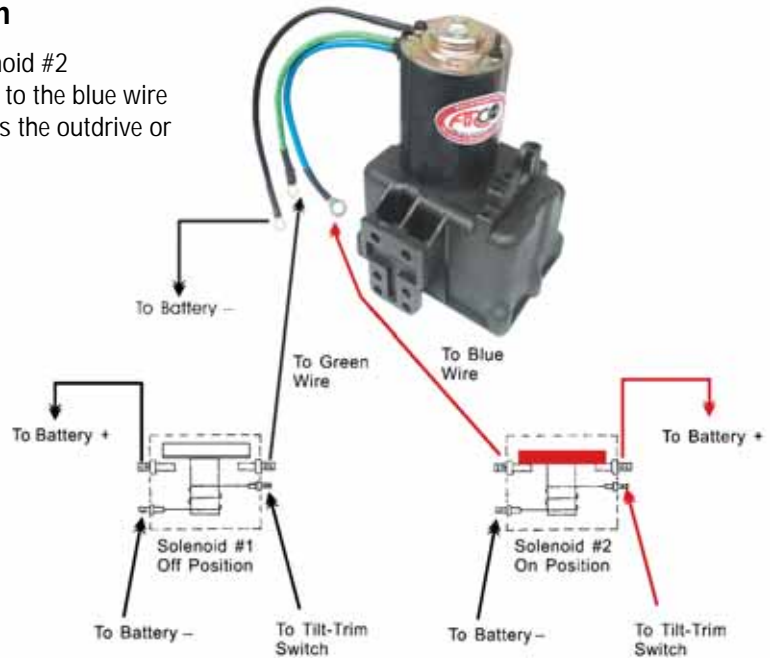

▼ Motor Running In The Down Direction

When the tilt-trim switch is in the down position, solenoid #1 is energized and battery positive voltage is supplied to the green wire making the motor run in the down direction. This lowers the outdrive or outboard motor.

